



Telefire Fire & Gas Detectors Ltd.

TFO-770A/TFO-770ALI

Analog Addressable Photoelectric Smoke Detector

Technical Manual



TELEFIRE FIRE & GAS DETECTORS LTD

P.O. Box 7036
Petah Tikva 49250
Israel

Tel: 972 3 921 1955

Fax: 972 3 921 1816

e-Mail: marketing@telefire.com

Web: www.telefire.com

Revision 1.01
January 2022

Notice and Disclaimer

© COPYRIGHT RESERVED BY TELEFIRE FIRE & GAS DETECTORS LTD.

TELEFIRE FIRE & GAS DETECTORS LTD. (TELEFIRE), ITS SUBSIDIARIES AND AFFILIATES, MAKE BUSINESSWISE REASONABLE EFFORTS TO ENSURE THAT THE INFORMATION IN THIS DOCUMENT IS ACCURATE AND UP TO DATE. TELEFIRE AND/OR ANYONE ACTING ON ITS BEHALF AND/OR ITS EMPLOYEES WILL **NOT** BE LIABLE FOR DAMAGES, CLAIMS, EXPENSES OR OTHER COSTS (INCLUDING AND WITHOUT LIMITATION EXPENSES FOR LEGAL FEES) ARISING FROM AND/OR RELATED TO THE USE OF THIS DOCUMENT OR THE INFORMATION CONTAINED IN OR RELATING TO IT. THIS LIMITATION OF LIABILITY APPLIES TO ALL DAMAGES OF ANY KIND, INCLUDING (WITHOUT LIMITATION) COMPENSATION, DIRECT AND/OR INDIRECT DAMAGES EXEMPLARY, PUNITIVE AND CONSEQUENTIAL DAMAGES, LOSS OF ANY SOFTWARE OR DATA, REVENUE OR PROFITS, OR ANY LOSS OR DAMAGE TO PROPERTY AND ANY CLAIMS OF THIRD PARTIES. TELEFIRE RESERVES THE RIGHT TO CHANGE THIS DOCUMENT AND OTHER DOCUMENTS MENTIONED FROM TIME TO TIME WITHOUT PRIOR NOTICE AND IN ITS SOLE DISCRETION. IT IS CLARIFIED THAT THE INTELLECTUAL PROPERTY RIGHTS FOR THIS DOCUMENT AND FOR THE PROPRIETARY TECHNOLOGY IN GENERAL BELONG TO TELEFIRE, INCLUDING COPYRIGHTS, TRADEMARK RIGHTS, INDUSTRIAL DESIGN RIGHTS AND PATENT RIGHTS. TELEFIRE DOES NOT LICENSE, ASSIGNS OR OTHERWISE GRANTS ANY OTHER INTEREST IN THE COPYRIGHTS OF THIS DOCUMENT, THE TRADEMARKS OF TELEFIRE, ANY OTHER TRADEMARK USED IN THIS DOCUMENT OR ANY OTHER INTELLECTUAL PROPERTY RIGHTS USED OR REFERENCED HERE, UNLESS TELEFIRE GRANTS IT IN AN EXPLICIT AND WRITTEN PERMISSION AGREEMENT. THIS DOCUMENT MAY RELATE TO OTHER DOCUMENTS, INCLUDING DOCUMENTS SUBJECT TO THE RIGHTS OF THIRD PARTIES. NOTHING IN THIS DOCUMENT CONSTITUTES THE GRANTING OF ANY LICENSE, ANY ASSIGNMENT AND/OR ANY OTHER INTEREST IN THE COPYRIGHTS OR OTHER INTELLECTUAL PROPERTY RIGHTS OF ANY OTHER DOCUMENT OF ANY KIND BY TELEFIRE.

i

Note

The intent and meaning of the term “**Trouble**” are as used in **NFPA 72** guideline and **UL** standard.

i

Note

Do not attempt to install, operate, maintain or inspect this product until you have read through this instruction manual and appended documents carefully and can use the equipment correctly. Do not use this product until you have a full knowledge of the equipment, safety information and instructions.

1 Introduction

Telefire's TFO-770A Analog Addressable Photoelectric Smoke Detector is an advanced detector that offers the following advantages:

- It is considered “green” (environment friendly) as it does not contain radioactive materials.
- The TFO-770A contains a powerful microprocessor that performs initial signal processing locally. The final processing and decision making is performed by the control panel.
- The TFO-770A's microprocessor offers a high level of noise immunity and interactively performs with the control panel drift compensation in order to overcome environmental changes and dust accumulation in the chamber. Once the detector is no longer able to compensate the control panel will display a trouble signal requesting cleaning. The microprocessor also performs signal processing, enables accurate control of the photoelectric chamber according to parameters set at the control panel, and manages the communication process with the control panel.
- The TFO-770A detector excels in sensing smoldering smoke and smoke from burning of various materials.
- Soft-set address – the detector's address is programmed into its memory without the use of mechanical switches or moving parts.
- Can be tested directly with a test magnet or remotely from the control panel.
- The detectors chamber and labyrinth can be cleaned in the field by authorized people.

The detector consists of a vented chamber (labyrinth), infrared and blue transmitters and a receiver that detects light scattering from the smoke particles in the chamber.

The sensitivity of the detector can be adjusted from the control panel within the range of 0.8% – 2.0%/foot (obscuration) in 0.2% increments. Please refer to the appropriate control panel manual for details.

The detector contains an alarm LED that has 360° visibility. This LED flashes during normal operation and is latched on during an alarm.

Short-Circuit Isolator

The TFO-770ALI includes all the functionality of the TFO-770A detector, with the addition of a built-in short-circuit isolator. After power up or reset of the system, the isolator checks for short-circuit condition. If no short-circuit is detected the isolator switches the circuit on and enables normal operation of the second connection of the SLC Loop.

Whenever a short-circuit condition occurs the Isolator opens the circuit automatically and disconnects the faulty side of the loop.

2 Compatibility

2.1 Control Panels

The TFO-770A is compatible with Telefire's 7000 Analog Addressable Control Panels family.

2.2 Bases

The TFO-770A is compatible with Telefire's TFB-180 Standard Detector Base.



Warning

Do not connect these detectors to control panels made by manufacturers other than Telefire.

3 Installation

Planning of quantity and location of detectors shall be done according to the local codes and regulations and in accordance to the planning consultant's requirements.

3.1 Pre-Installation Planning

3.1.1 Capacity Planning

Ensure that the total number of initiating devices (detectors, switches, call point, etc.) does not exceed the maximum allowed per detection zone, floor area, or other limitations as specified by the applicable standards and regulations. Ensure that the Control Panel has an available address for each detector.

3.1.2 Cabling Planning

The detector is connected to the control panel via a TFB-180 standard detector base via a two-wire connection (the control panel's SLC loop). The detector has an output for activating a TFL-1AN Auxiliary Signaling Indicator for Analog Addressable Detectors. It is recommended that you use a twisted pair cable for SLC connection.

NOTE: TFO-770A and TFO-770ALI require different SLC connections, as described below:

Connection diagram for smoke detector TFO-770A

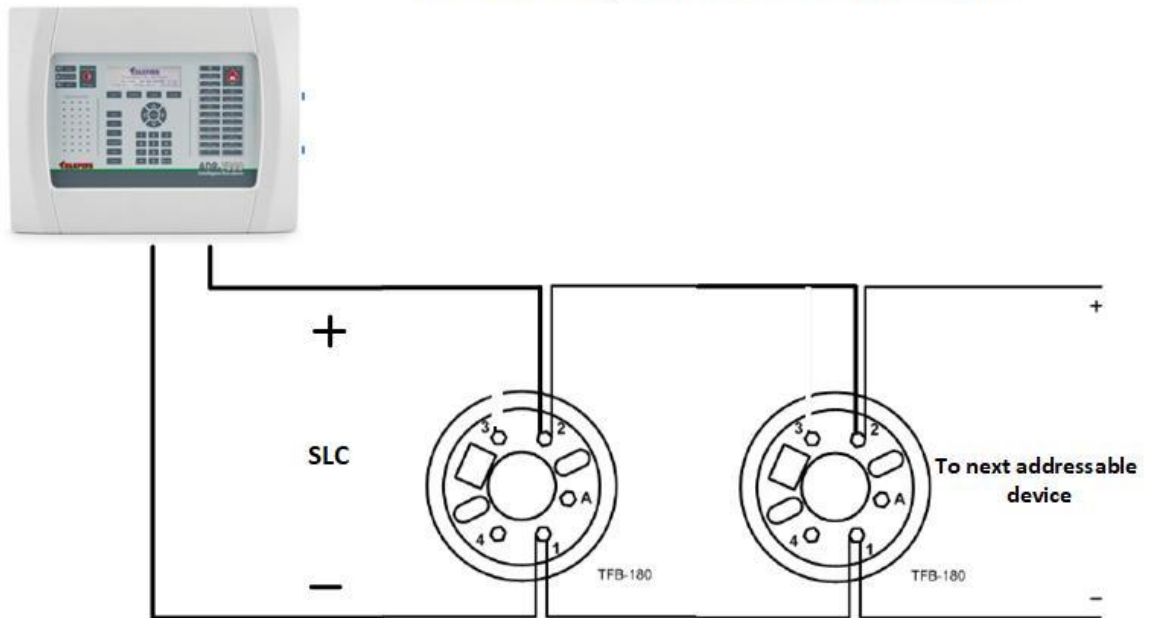

Connection diagram for smoke detector TFO-770ALI

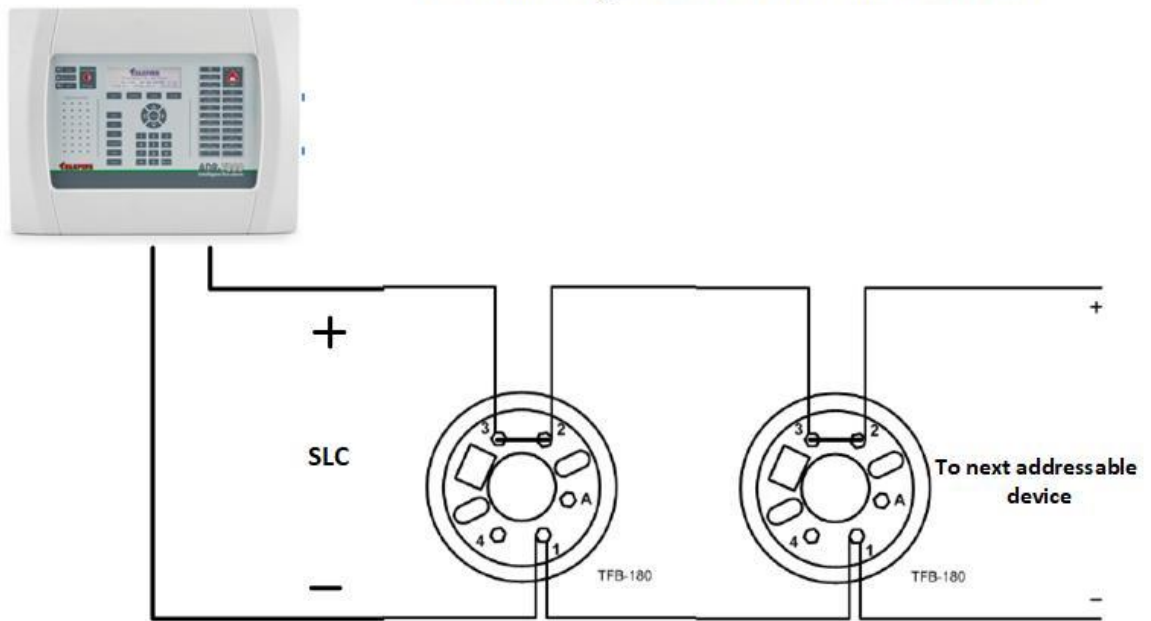
*i***Note**

Notify the operator or the security personnel that the system will be temporary disconnected before adding detectors to the control panel.

3.2 Installation

3.2.1 Address Programming

Assign the TFO-770A's address in the range of 1 – 127 prior to installation either by using the PROG-4000 Analog Addressable Detector and Accessory Programmer or directly from the Control Panel built-in programmer. Please refer to the PROG-4000 manual or Control Panel manual for additional details.

3.2.2 Control Panel Configuration

Configure the detector as "**Photoelectric Detector**" in the Control Panel. Configure the detector's sensitivity at the control panel ("0.8" – most sensitive, "2.0" – least sensitive"), if required.

Please refer to the Control Panel technical manual for a detailed description of programming and configuration.

3.2.3 Location

The TFO-770A is designed to protect indoor fire risk areas, except environments where smoke, steam, dust, or corrosive gasses are present under normal conditions.

Photoelectric smoke detectors should be used for detecting smoldering fires in corridors and along escape routes, wood- or paper stores, electric cabinets, etc., They should not be used in steamy, dusty, or smoky areas such as kitchens, bathrooms, saunas, laundries, etc.

Consider NFPA 72 guidelines and local fire codes when installing the TFO-770A.

When installing a TFO-770A smoke detector on a slanted (up to 45°) ceiling that allows free flow of smoke (i.e., there are no beams or other obstacles) the detector should be

installed parallel to the flow line of the ceiling, and not horizontally. For ceilings with impediments to free smoke flow please refer to the relevant local fire code standard.

Use only Telefire's TFB-180 Standard Detector Base.

For remote signaling use only Telefire's TFL-1NA Auxiliary Signaling Indicator for Analog Addressable Detectors.

UL**UL Requirement**

Smoke detectors are not to be used with detector guards unless the combination has been evaluated and found suitable for that purpose.

3.2.4 Connecting to the SLC Line

Connect the SLC to the detector's base. Refer to the TFB-180 technical manual for wiring diagrams.

All wiring must conform to applicable local codes, ordinances and regulations.

i**Note**

Measure the wiring to ensure there are no shorts before connecting the wiring to the control panel.

Connecting or adding detectors to the control panel shall be done when all power to the control power (AC and batteries) is disconnected.

3.2.5 Detectors Initialization

It is recommended that you perform detector initialization after initial system activation, adding, or replacing detectors in order to reduce system stabilization time. If you do not perform this action, it will be done automatically within several hours of normal operation. Please see the control panel's technical manual for an explanation on performing Detectors Init.

i**Note**

Ensure that detector initialization is performed when all detectors are in a smoke-free condition.

3.3 Post-Installation – Field Test

Perform a field test (also known as "Walk Test") to ensure that all detectors function properly. Please see the control panel's manual for a detailed explanation on how to perform a field test.

Testing is automatic other than the activation of the detector that is done manually by putting a magnet next to the detector's test point. See section 4.1.1 for a detailed explanation on how to perform the test.

Ensure that the detector functions properly and is included in the necessary activation matrices.

!**Warning**

Do not apply naked flame to the detector!

3.4 Documentation

Mark the detector's address on the label.

4 Maintenance

The control panel monitors the analog detectors continuously. Any abnormal condition in the detector will cause a trouble signal to be displayed on the control panel.

When a detector becomes contaminated to a degree that cannot be compensated, the control panel will display a maintenance trouble signal. At this point the detector must be cleaned.



Note

Please check the detector's value in the control panel's MONITOR screen. If the value is higher than 103, replace the detector. The detector should be cleaned if it is lower than 61.

4.1 Periodic Testing

Fire alarm systems should be checked periodically. Please refer to NFPA and local fire codes to determine service frequency.

Use the control panel's Walk Test mode to perform automatic reset. Please refer to the control panel's manual for additional details on how to perform Walk Test.

4.1.1 Test Procedure – Locally

1. Apply a magnet to the side of the detector next to the LED for 3 – 5 seconds. This activates an internal testing circuit that simulates presence of smoke in the detector, tests the sensing mechanism and the detector's electronic circuit.



Warning

Do not apply naked flame to the detector!

2. The analog value representing the smoke level will be transmitted to the control panel for evaluation. The control panel will transmit a signal to the detector to turn on its LED. During the test the detector's values may be observed at the control panel. Please refer to the Control Panel manual for additional information.
3. Once the detector is in alarm mode, it keeps the alarm condition until reset by the control panel. If the control panel is in "Walk Test" mode, it will reset the alarm after a few seconds. Please refer to the Control Panel manual for instructions on how to conduct a walk test.

4.1.2 Test Procedure – From the Control Panel

It is also possible to test the detector using the Control Panel "Monitor" option menu. Please refer to the Control Panel manual for instructions on how to use and interpret the monitor screen.



Note

Testing detectors with an aerosol spray may cause increased contamination in the labyrinth chamber due to accumulation of oil residue and dust. This accumulation may shorten the detectors life-span and require it to be sent to the factory for cleaning.

4.2 Detector Cleaning

Contamination is a by-product of normal operation and may be caused by various sources, most of which are impossible to eliminate. Normal human activity creates a constant source of airborne dust and dirt that over a period of time may affect the detector's performance.

Analog detectors should be cleaned when a maintenance signal appears on the control panel. Local regulations may specify an interval period for maintenance schedule.

The TFO-770A's chamber is removable and can be cleaned or replaced. Cleaning should be done by qualified personnel in order to ensure that the detector is properly handled, reassembled correctly and tested for proper operation.

5 Indications and Troubleshooting

The detector includes an indicating LED that flashes with every access from the control panel and is turned solid on during alarm.

A detailed message will also be displayed on the control panel and remote annunciators. Please see the control panel's manual for a detailed explanation of alarm, fault, and maintenance alarm indication.

6 Specification

Diameter	101 mm including base
Height (including base and LED).....	52 mm
Weight	106 gr.
Operating Temperature Range	0°C – +60°C (32°F – 140°F)
Relative Humidity Range	10% – 93% non-condensing
Sensitivity Range (set at control panel)	0.8 – 2.0%/foot obscuration
Operating Voltage (supplied by control panel via SLC).....	19 – 22 VDC, Modulated
Maximum Current Consumption:	
TFO-770A Quiescence mode.....	180µA
TFO-770AIL Quiescence mode.....	380µA
Alarm mode (without Auxiliary Indicators)	3mA max.
Alarm mode (3 Auxiliary Indicators)	35mA

Local Indication Local red LED (light-emitting diode) and an auxiliary indicator output. Use only Telefire's TFL-1AN Auxiliary Indicator for Analog Addressable Conventional Detectors. Connect up to 5 auxiliary indicators to each detector.

Only devices approved by TELEFIRE are allowed to be connected

TELEFIRE reserves the right to modify product specifications without prior notice

7 Certification

Telefire's TFO-770A Analog Addressable Photoelectric Smoke Detector has the following approvals:

- UL 268 Listed – In process
- EN 54-7, EN 54-17 certification – In process
- Standards Institution of Israel SII-1220