

**TELEFIRE**

Telefire Fire &amp; Gas Detectors Ltd.

# TPS-74A

## Addressable Auxiliary Power Supply

### Technical Manual

**TELEFIRE FIRE & GAS DETECTORS LTD**

PO Box 7036  
Petach Tikva 49250  
Israel

Tel: 972 3 970 0400  
Fax: 972 3 921 1816  
eMail: [info@telefire.com](mailto:info@telefire.com)  
Web: [www.telefire.com](http://www.telefire.com)

TPS-74AEn100.pdf

**Revision 1.01****ReIDate****10/2022**

Date	Revision	Written by	Reviewed by	Approved by
10/2022	1.01	Motti Drori/Ami Holtzman	Boris Gitelman	Dov Zelig

## Notice and Disclaimer

### © COPYRIGHT RESERVED BY TELEFIRE FIRE & GAS DETECTORS LTD.

TELEFIRE FIRE & GAS DETECTORS LTD. (TELEFIRE), ITS SUBSIDIARIES AND AFFILIATES, MAKE BUSINESSWISE REASONABLE EFFORTS TO ENSURE THAT THE INFORMATION IN THIS DOCUMENT IS ACCURATE AND UP TO DATE. TELEFIRE AND/OR ANYONE ACTING ON ITS BEHALF AND/OR ITS EMPLOYEES WILL **NOT** BE LIABLE FOR DAMAGES, CLAIMS, EXPENSES OR OTHER COSTS (INCLUDING AND WITHOUT LIMITATION EXPENSES FOR LEGAL FEES) ARISING FROM AND/OR RELATED TO THE USE OF THIS DOCUMENT OR THE INFORMATION CONTAINED IN OR RELATING TO IT. THIS LIMITATION OF LIABILITY APPLIES TO ALL DAMAGES OF ANY KIND, INCLUDING (WITHOUT LIMITATION) COMPENSATION, DIRECT AND/OR INDIRECT DAMAGES EXEMPLARY, PUNITIVE AND CONSEQUENTIAL DAMAGES, LOSS OF ANY SOFTWARE OR DATA, REVENUE OR PROFITS, OR ANY LOSS OR DAMAGE TO PROPERTY AND ANY CLAIMS OF THIRD PARTIES. TELEFIRE RESERVES THE RIGHT TO CHANGE THIS DOCUMENT AND OTHER DOCUMENTS MENTIONED FROM TIME TO TIME WITHOUT PRIOR NOTICE AND IN ITS SOLE DISCRETION. IT IS CLARIFIED THAT THE INTELLECTUAL PROPERTY RIGHTS FOR THIS DOCUMENT AND FOR THE PROPRIETARY TECHNOLOGY IN GENERAL BELONG TO TELEFIRE, INCLUDING COPYRIGHTS, TRADEMARK RIGHTS, INDUSTRIAL DESIGN RIGHTS AND PATENT RIGHTS. TELEFIRE DOES NOT LICENSE, ASSIGNS OR OTHERWISE GRANTS ANY OTHER INTEREST IN THE COPYRIGHTS OF THIS DOCUMENT, THE TRADEMARKS OF TELEFIRE, ANY OTHER TRADEMARK USED IN THIS DOCUMENT OR ANY OTHER INTELLECTUAL PROPERTY RIGHTS USED OR REFERENCED HERE, UNLESS TELEFIRE GRANTS IT IN AN EXPLICIT AND WRITTEN PERMISSION AGREEMENT. THIS DOCUMENT MAY RELATE TO OTHER DOCUMENTS, INCLUDING DOCUMENTS SUBJECT TO THE RIGHTS OF THIRD PARTIES. NOTHING IN THIS DOCUMENT CONSTITUTES THE GRANTING OF ANY LICENSE, ANY ASSIGNMENT AND/OR ANY OTHER INTEREST IN THE COPYRIGHTS OR OTHER INTELLECTUAL PROPERTY RIGHTS OF ANY OTHER DOCUMENT OF ANY KIND BY TELEFIRE.

### Note

This product has been designed to comply with the requirements of the Low Voltage Safety and the EMC Directives. Failure to follow the installation instructions may compromise its adherence to these standards.

### Note

Only trained service personnel should undertake the Installation, Programming and Maintenance of this equipment. Do not use this product until you have a full knowledge of the equipment, safety information and instructions.

## 1 Introduction

The TPS-74A is an auxiliary power supply that is fed from a 230Vac input and includes a 24Vdc 100W power supply, battery charger, and a control card that monitors the TPS-74A and reports status and trouble information to the control panel. Reporting is done via the SLC loop and the TPS-74A takes up an address of the loop's address range. The TPS-74A's output is used when the total demand on the control panel's 24Vdc power supply exceeds its capacity, or to power I/O modules, sounders, or special detectors that are installed a long distance from the control panel. The TPS-74A's 24Vdc output allows for up to 3.5A current draw during alarm.

The power supply consists of a chassis that contains two 12V sealed lead-acid batteries in capacity of up to 14AH, and up to 14 (W) by 9.5 (D) by 17 (H) cm each, a 100W power supply, and a printed circuit board that monitors and controls AC voltage, battery charging / discharging and SLC communication with the control panel.

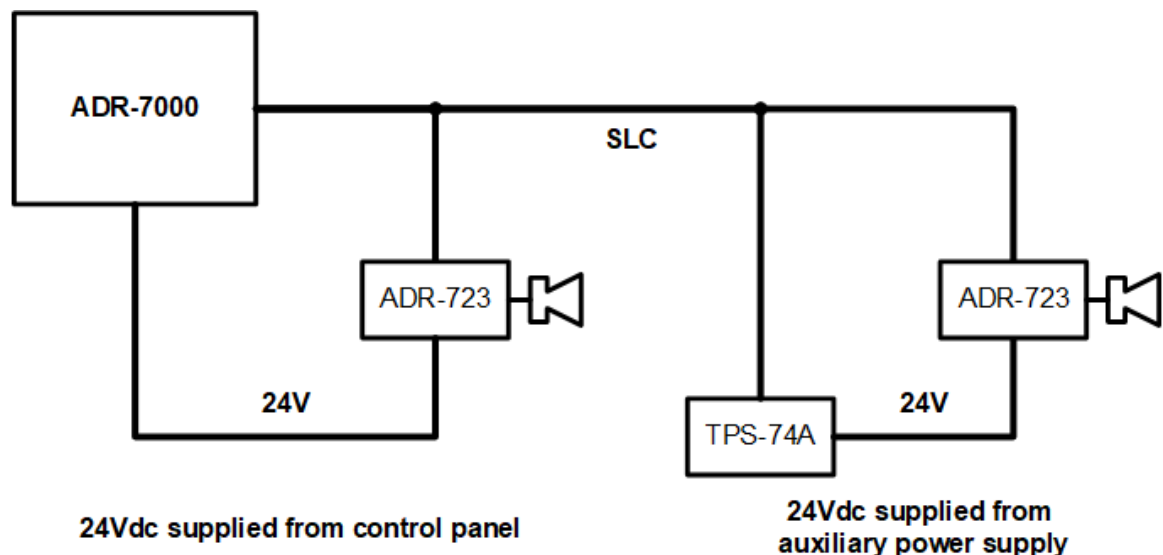

Figure 1 Example of TPS-74A connection

## 2 Compatibility

### 2.1 Control Panels

The TPS-74A is compatible with the full range of Telefire fire alarm control panels. Connecting the SLC to an addressable panel will allow supervision of the auxiliary power supply's status and faults.

### 2.2 Devices

The TPS-74A is compatible with all Telefire devices that require 24Vdc supply.

## 3 Installation

Large fire detection and alarm systems that require high current 24Vdc power may be expanded by installing TPS-74A auxiliary power supplies. These power supplies may be used to add 24Vdc power to the system.

### 3.1 Telefire's 7000 Control Panels

Auxiliary power supplies are required if at least one of the following conditions are met:

- Current draw from a single 24Vdc output is more than 0.5A in quiescence mode or 1.5A in alarm
- The total power consumption of the control panel (the control panel itself and devices attached and powered by it) is more than 5.25A
- There is a requirement for batteries with more than 18AH capacity
- Voltage drop to the last device fed by the 24Vdc output is more than 2V, or does not provide high enough voltage at the last device to operate it

### 3.2 ADR-3000 Control Panels

Auxiliary power supplies are required if at least one of the following conditions are met:

- Current draw from the 24Vdc outputs is more than 0.5A in quiescence mode or 1.5A in alarm
- The total power consumption of the control panel (the control panel itself and devices attached and powered by it) is more than 4.0A in alarm
- There is a requirement for batteries with more than 14AH capacity
- Voltage drop to the last device fed by the 24Vdc output is more than 2V, or does not allow high enough voltage at the last device to operate it

### 3.3 Pre-Installation Planning

#### 3.3.1 Battery capacity

The power supply can charge a pair of sealed lead-acid of 24Vdc (two 12Vdc batteries) and capacity of up to 14AH.

#### 3.3.2 Capacity Planning

Ensure that the control panel has a free address for the TPS-74A.

#### 3.3.3 Cabling Planning – Wire Characteristics' Effect on System Performance

The following table shows the effect of wiring characteristics on system performance:

Characteristic	Effect on SLC	Effect on IDC
Electric resistance	Minimal	Minimal
Capacitance	High	No affect
Inductance	High	Minimal
Mechanical Strength	High	High

Table 1 Wire Characteristics' Effect on System Performance

#### 3.3.4 Cabling Planning – Signaling Line Circuits (SLC)

The TPS-74A connects to the control panel via a two-wire cable 18 AWG (cross section of 0.8mm<sup>2</sup>). Twisted-pair cable is recommended.

Wire Size	Cross Section (mm <sup>2</sup> )	Maximum SLC branch length for wire size
18 AWG	0.8 mm <sup>2</sup>	950 m

Table 2 Selecting SLC Wires

### 3.3.5 Cabling Planning – 24Vdc Out

Use a 2-wire cable, 12 – 18 AWG (0.8 to 3.3 mm<sup>2</sup>) for 24Vdc Out connections.

The length of activation lines and 24Vdc out cabling depends on the required current and cable size. Ensure that the maximum voltage drop to the end of the line at full load does not exceed 2V and will leave the last device the minimal operating voltage as per the manufacturer's specification.

*i*

**Note**

TPS-74A Analog Addressable Auxiliary Power Supplies should be installed as close as possible to the devices they activate to reduce power loss. TPS-74A auxiliary power supplies should not be shared between multiple control panels or between line cards on the same control panel. TPS-74A auxiliary power supplies may be shared between the two loops of a single ADR-3002C line card.

## 3.4 Installation and Connection

*i*

**Note**

Notify the operator or the security personnel that the system will be temporary disconnected before adding devices to the control panel.

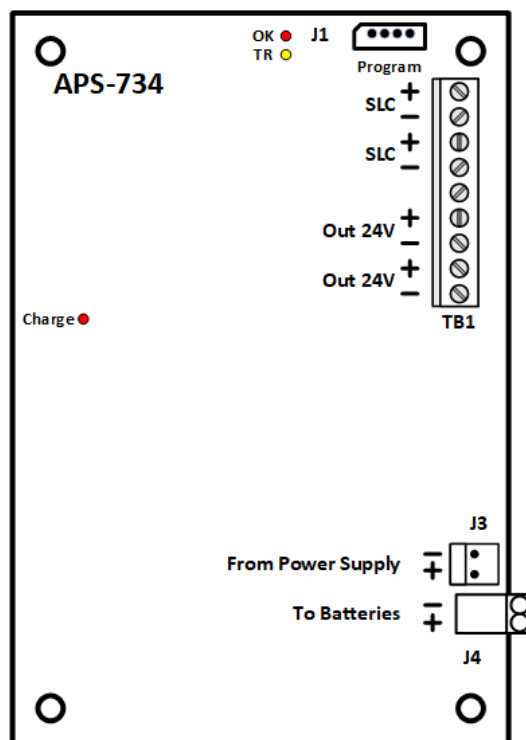

Figure 2 Connection diagram

Connect the power supply's AC input line to a dedicated circuit breaker that is not shared by other appliances or equipment. It is recommended that the circuit breaker shall be labeled "FIRE ALARM".

The power cable should enter the control panel through either the top left or bottom left knockout opening and separated from the SLC wiring. Use a plastic bushing that fits the opening. Connect the Live and Neutral wires to the proper terminal. Connect the Ground wire directly to the panel's chassis using the marked ground screw.

### 3.4.1 Address Programming

Configure the power supply's address using a Telefire PROG-4000 programmer.

### 3.4.2 Configuring the Control Panel

Define the power supply's address **Power Supply**. Please see the control panel's technical manual for additional information on device configuration.

### 3.4.3 Locating the Power Supply

The power supply should be installed in a closed location. Avoid exposure to outdoor environment to prevent high humidity or dust or air pollution.

### 3.4.4 Connection

Connect the SLC, 24Vdc outputs, and AC main.

## 3.5 Post-Installation

### 3.5.1 Test

Verify the devices powered by the power supply operate as required in quiescence condition, and can provide the required current to devices powered by them.

## 3.6 Connectors and Indicators

The APS-734 has five connectors:

TB	Function
TB1	This connector has 4 connection: two for the SLC, and a pair of two 24V cables for 24Vdc supply to devices in the field.
J1	Connector for address programming
J4	Battery connection
J3	100W power supply connection

## 3.7 Indication LEDs

The APS-734 has three LEDs:

- **OK** (red LED) – indicates that the power supply is addressed by the control panel
- **TR** (yellow LED) – indicates a fault
- **Charging** (red LED) – on when the batteries are being charged

The control panel will display a detailed error message on its LCD

## 4 Specification

Dimensions (W / H / D) .....	465 / 260 / 125 mm
Operating Temperature range.....	-10°C – +60°C (14°F – 140°F)
Operating Voltage.....	110-230Vac +10%/-15%; 50-60Hz
SLC Voltage .....	21V, modulated
Max 24Vdc to devices	
in compliance with UL 864 .....	3.5A

**All values are nominal. Specifications are subject to change without prior notice**

## 5 Certification

Telefire's TPS-74A has the following approvals:

- UL 864 approved
- EN 54-4 / EN 54-18 approved