



Telefire Fire & Gas Detectors Ltd.

# TLD-08

## Addressable Switch / Output Module

### Technical Manual

**TELEFIRE FIRE & GAS DETECTORS LTD**

PO Box 7036  
Petach Tikva 49250  
Israel

Tel: 972 3 970 0400  
Fax: 972 3 921 1816  
eMail: [info@telefire.co.il](mailto:info@telefire.co.il)  
Web: [www.telefire.co.il](http://www.telefire.co.il)

TLD-08En103.pdf

**Revision 1.03**  
**RelDate 10/2022**

Date	Revision	Written by	Reviewed by	Approved by
10/2022	1.01	Motti Drori/Ami Holtzman	Boris Gitelman	Dov Zelig

## Notice and Disclaimer

### © COPYRIGHT RESERVED BY TELEFIRE FIRE & GAS DETECTORS LTD.

TELEFIRE FIRE & GAS DETECTORS LTD. (TELEFIRE), ITS SUBSIDIARIES AND AFFILIATES, MAKE BUSINESSWISE REASONABLE EFFORTS TO ENSURE THAT THE INFORMATION IN THIS DOCUMENT IS ACCURATE AND UP TO DATE. TELEFIRE AND/OR ANYONE ACTING ON ITS BEHALF AND/OR ITS EMPLOYEES WILL **NOT** BE LIABLE FOR DAMAGES, CLAIMS, EXPENSES OR OTHER COSTS (INCLUDING AND WITHOUT LIMITATION EXPENSES FOR LEGAL FEES) ARISING FROM AND/OR RELATED TO THE USE OF THIS DOCUMENT OR THE INFORMATION CONTAINED IN OR RELATING TO IT. THIS LIMITATION OF LIABILITY APPLIES TO ALL DAMAGES OF ANY KIND, INCLUDING (WITHOUT LIMITATION) COMPENSATION, DIRECT AND/OR INDIRECT DAMAGES EXEMPLARY, PUNITIVE AND CONSEQUENTIAL DAMAGES, LOSS OF ANY SOFTWARE OR DATA, REVENUE OR PROFITS, OR ANY LOSS OR DAMAGE TO PROPERTY AND ANY CLAIMS OF THIRD PARTIES. TELEFIRE RESERVES THE RIGHT TO CHANGE THIS DOCUMENT AND OTHER DOCUMENTS MENTIONED FROM TIME TO TIME WITHOUT PRIOR NOTICE AND IN ITS SOLE DISCRETION. IT IS CLARIFIED THAT THE INTELLECTUAL PROPERTY RIGHTS FOR THIS DOCUMENT AND FOR THE PROPRIETARY TECHNOLOGY IN GENERAL BELONG TO TELEFIRE, INCLUDING COPYRIGHTS, TRADEMARK RIGHTS, INDUSTRIAL DESIGN RIGHTS AND PATENT RIGHTS. TELEFIRE DOES NOT LICENSE, ASSIGNS OR OTHERWISE GRANTS ANY OTHER INTEREST IN THE COPYRIGHTS OF THIS DOCUMENT, THE TRADEMARKS OF TELEFIRE, ANY OTHER TRADEMARK USED IN THIS DOCUMENT OR ANY OTHER INTELLECTUAL PROPERTY RIGHTS USED OR REFERENCED HERE, UNLESS TELEFIRE GRANTS IT IN AN EXPLICIT AND WRITTEN PERMISSION AGREEMENT. THIS DOCUMENT MAY RELATE TO OTHER DOCUMENTS, INCLUDING DOCUMENTS SUBJECT TO THE RIGHTS OF THIRD PARTIES. NOTHING IN THIS DOCUMENT CONSTITUTES THE GRANTING OF ANY LICENSE, ANY ASSIGNMENT AND/OR ANY OTHER INTEREST IN THE COPYRIGHTS OR OTHER INTELLECTUAL PROPERTY RIGHTS OF ANY OTHER DOCUMENT OF ANY KIND BY TELEFIRE.

### Note

This product has been designed to comply with the requirements of the Low Voltage Safety and the EMC Directives. Failure to follow the installation instructions may compromise its adherence to these standards.

### Note

Only trained service personnel should undertake the Installation, Programming and Maintenance of this equipment. Do not use this product until you have a full knowledge of the equipment, safety information and instructions.

# 1 Introduction

The multi I/O module family is intended for use where there is a need for multiple outputs and switch inputs for supervision and indication purpose, such as.

The module has multiple operating modes that are selectable via switches or jumpers on the modules, and may include number of addresses, or switch input modes. The module occupies 4, 8, 16, or 24 consecutive addresses, depending on setting and hardware combination.

The module communicates with the control panel and is controlled by it, and receives 24Vdc supply from the control panel.

The product family consists of a main card, and optionally one of 3 daughter boards that are mounted on it.

- TLD-08 – main board. Includes SLC connectors, 24Vdc connectors, and 8 unsupervised open collector outputs. It also contains switches or jumpers for configuration.
- TLD-E16 – a 16 open collector expansion module
- TLD-R8 – an 8 dry contact relay module. These relays have the same 8 addresses as the main card's open collector outputs, and are activated by the same logic conditions.
- TSM-E16 – a 16 switch input add on module.

Configuration	Inputs	OC outputs	Relays	Address range <sup>1</sup>
TLD-08	None	8	None	4 or 8
TLD-08 + TLD-E16	None	24	None	16 or 24
TLD-08 + TLD-R8	None	8	8	4 or 8
TLD-08 + TSM-E16	16	8	None	16 or 24

# 2 Compatibility

## 2.1 Control Panels

The TLD-24 product family is designed to work with Telefire's addressable control panels.

## 2.2 Inputs

Connect only switches or approved devices to the TSM-E16 inputs.

## 2.3 Outputs

Connect indicating LEDs to the open collector outputs.

---

<sup>1</sup> Selectable via jumpers or switches. See section 3.2.1

Connect relevant devices to the module's relays provided they do not have more than nominal 30Vdc.

### 3 Installation

Planning of quantity and location of detectors and call points shall be done according to the local codes and regulations and in accordance to the planning requirements.



**Warning**

**Disconnect all power supplies, main and batteries before connecting or disconnecting cables and devices to the control panel.**

#### 3.1 Pre-Installation Planning

The module requires a four-wire connection: one pair for SLC communication with the control panel via SLC, and one pair for 24Vdc supply from the control panel or an auxiliary power supply such as the TPS-74A. Twisted-pair cable is recommended.

##### 3.1.1 Capacity Planning

Ensure that the control panel has sufficient free consecutive addresses for the equipment being added. The TLD-24 can occupy 4, 8, 16, or 24 consecutive addresses, dependent on hardware and switch configuration. See section 3.2.1 on page 4 for details about setting address ranges.

##### 3.1.2 Cabling Planning – Wire Characteristics' Effect on System Performance

Cable type selection and wiring shall be done according to local regulations.

System connections shall be done when power sources are disconnected.

Changing/installing electric activation modules shall be done after the system is in quiescence state (push buttons and detectors in normal state).

Characteristic	Effect on SLC	Effect on IDC	Effect on Outputs
Electric Resistance	Minimal	Minimal	Very High
Capacitance	High	No effect	No Influence
Inductance	High	Minimal	Minimal
Mechanical Strength	High	High	High

##### 3.1.3 Cabling Planning – Signaling Line Circuits (SLC)

The module connects to the control panel via a two-wire cable. Use a fire-resistant cable that is 12 – 20 AWG (cross section of 0.5mm<sup>2</sup> to 3.3mm<sup>2</sup>). Twisted-pair cable is recommended.

AWG	Dia (mm <sup>2</sup> )	Cross (mm <sup>2</sup> )	Maximum SLC length
20	0.812	0.518	570m / 1,630 feet
19	0.912	0.653	710m / 2,040 feet
18	1.024	0.823	900m / 2,580 feet
17	1.150	1.04	1,125m / 3,230 feet
16	1.291	1.31	1,425m / 4,090 feet

AWG	Dia (mm <sup>2</sup> )	Cross (mm <sup>2</sup> )	Maximum SLC length
15	1.450	1.65	1,800m / 5,170 feet
14	1.628	2.08	2,275m / 6,530 feet
13	1.828	2.62	2,875m / 8,260 feet
12	2.053	3.31	3,625m / 10,410 feet

### 3.1.4 Cable Planning – 24Vdc Supply from Control Panel or Auxiliary Power Supply

The module requires 24Vdc from the control panel or a UL listed auxiliary power supply. Use a UL listed auxiliary power supply whenever the module is installed a long distance from the control panel or whenever the total current consumption of all NACs exceeds the capability of the control panel's 24Vdc output.

Use a fire-resistant cable that is 12 – 20 AWG (cross section of 0.5mm<sup>2</sup> to 3.3mm<sup>2</sup>).

### 3.1.5 Cable Planning – Module Inputs

The module connects to the initiating device via a two-wire cable. Use a fire-resistant cable that is 12 – 20 AWG (cross section of 0.5mm<sup>2</sup> to 3.3mm<sup>2</sup>). The initiating device should be no farther than 10m and in the same room as the ADR-723.

### 3.1.6 Cabling Planning – Module Outputs

Use a 2-wire fire-resistant cable that is 12 – 20 AWG (cross section of 0.5mm<sup>2</sup> to 3.3mm<sup>2</sup>) for Activation Lines and 24Vdc Out connections.

The length of activation lines and 24Vdc out cabling depends on the required current and cable size. Ensure that the maximum voltage drop to the end of the line at full load does not exceed 2V and will leave the last device the minimal operating voltage as per the manufacturer's specification.

*i*

**Note**

- When supplying 24Vdc power from a UL listed auxiliary power supply use a two-wire SLC connection (+SLC, -SLC) and a two-wire 24Vdc supply (+24V and -24V)
- 24Vdc cables that supply voltage to several loops shall be split only at the control panel. Do not interconnect 24Vdc cables to multiple loops away from the control panel.
- UL listed auxiliary power supplies should be installed as close as possible to the devices they activate to reduce power loss.
- UL listed auxiliary power supplies should not be shared between multiple control panels or between line cards on the same control panel. UL listed auxiliary power supplies may be shared between the two loops of a single ADR-3002C line card.

### 3.1.7 Activation Matrices Planning

Plan the activation logic according to the requirements of the consultant.

### 3.1.8 Cabling Planning – 24Vdc Supply

The module requires 24Vdc from the addressable control panel or an auxiliary power supply such as the TPS-74A.

Use an auxiliary power supply such as the TPS-74A whenever the module is installed a long distance from the addressable control panel or whenever the total current consumption of all NACs exceeds the capability of the addressable control panel's 24Vdc output.

### 3.1.9 Cabling Planning – Initiating Device Circuit (IDC – Zones)

The module connects to the initiating device via a two-wire cable 12 – 18 AWG (cross section of 0.8mm<sup>2</sup> to 3.3mm<sup>2</sup>).

Wire Size	Cross Section (mm <sup>2</sup> )	Maximum IDC length for wire size
18 AWG	0.8 mm <sup>2</sup>	1,200 m
16 AWG	1.3 mm <sup>2</sup>	1,900 m
14 AWG	2.1 mm <sup>2</sup>	3,000 m
12 AWG	3.3 mm <sup>2</sup>	4,800 m

Table 1 Selecting IDC (input) Wires

## 3.2 Installation

*i*

**Note**

Notify the operator or the security personnel that the system will be temporary disconnected before adding devices to a control panel.

Measure the wiring to ensure there are no shorts before connecting the wiring to the control panel.

Connecting or adding devices to a control panel shall be done when all power to the control power (AC and batteries) is off.

### 3.2.1 Module Configuration and Addressing

The module occupies 4, 8, 16, or 24 consecutive addresses, depending on the specific hardware configuration and dip switches or jumper setting.



Figure 1 Configuration jumpers and switches – TLD-08 module

JP1-1 or SW1-1	JP1-2 or SW1-2	Address range	Active addresses		
			Lower card	Top card (TLD-E16 or TSM-E16)	Top Card (TLD-R8)
Open jumper or DIP Switch Off	Open jumper or DIP Switch Off	4	4	None	4 <sup>2</sup>

<sup>2</sup> The TLD-R8 occupies the same addresses as the bottom card.

JP1-1 or SW1-1	JP1-2 or SW1-2	Address range	Active addresses		
			Lower card	Top card (TLD-E16 or TSM-E16)	Top Card (TLD-R8)
Open jumper or DIP Switch Off	Closed jumper or DIP Switch ON	8	8	None	8
Closed jumper or DIP Switch ON	Open jumper or DIP Switch Off	16	8	8	N / A
Closed jumper or DIP Switch ON	Closed jumper or DIP Switch ON	24	8	16	N / A

**Table 2 Address space**

### 3.2.2 TSM-E16 configuration



**Figure 1 Configuration jumpers and switches – TSM-E16 module**

JP1-1 or SW1-1	JP1-2 or SW1-2	Work Mode
Open jumper or DIP Switch Off	Open jumper or DIP Switch Off	NO switch; no supervision for short or open circuit. A short is considered as activation
Open jumper or DIP Switch Off	Closed jumper or DIP Switch ON	NO switch; full line supervision. 20KΩ EoL and 3.9K resistor for activation.
Closed jumper or DIP Switch ON	Open jumper or DIP Switch Off	NO switch, no supervision for shorts. 20KΩ EoL. A short is considered as activation
Closed jumper or DIP Switch ON	Closed jumper or DIP Switch ON	N / A

**Table 3 Module configuration**

**i**

**Note**

When the TSM-E16 is configured without supervision for shorts (JP1-2 open or SW1-2 is Off), the IDC line is limited to the same room or no farther than 10m. A short is considered as activation.

When the TSM-E16 is configured for supervision for shorts (JP1-2 is jumpered or SW1-2 is On), the IDC line can be up to 100m, depending on cable type. A short is considered as a fault, and 3.9K resistance is considered as activation.

### 3.2.3 Address programming\

Configure the module's first address using a PROG-4000 or the control panel's address programming port.

### 3.2.4 Control Panel Definition – Inputs

Define the module's inputs as **Switch**, and the mode as **Alarm** (activation will cause an alarm), **Reset** (will allow resetting the control panel), **Silence** (will silence NACs), **Disconnect** (will report a supervisory even in the event of extinguishing disconnect), **Supervisory** (any supervisory input), **Abort** (abort release), **Release** (activate release), **Alarm MTX** (alarm matrix), **Fan FC** (fan flow control), or **Speaker** (speaker switching input), as appropriate.

### 3.2.5 Control Panel Definition – Outputs

Define the module's outputs as **Lamp**, **Supervisory Output**, or **Control Out**, as appropriate.

If the output is defined as **Control Out**, define the mode as **Alarm**, **Fault**, **Fan**, **Damper** (Damper activation), or **Speaker** (speaker switching), as appropriate

Configure the control panel's activation matrices as required. Please see the control panel's instruction manual for explanation on control panel configuration.

### 3.2.6 Location

The module should be installed in a closed location. Avoid exposure to outdoor environment to prevent high humidity or dust or air pollution.

### 3.2.7 Connect the SLC

Connect the SLC from the control panel or previous device.

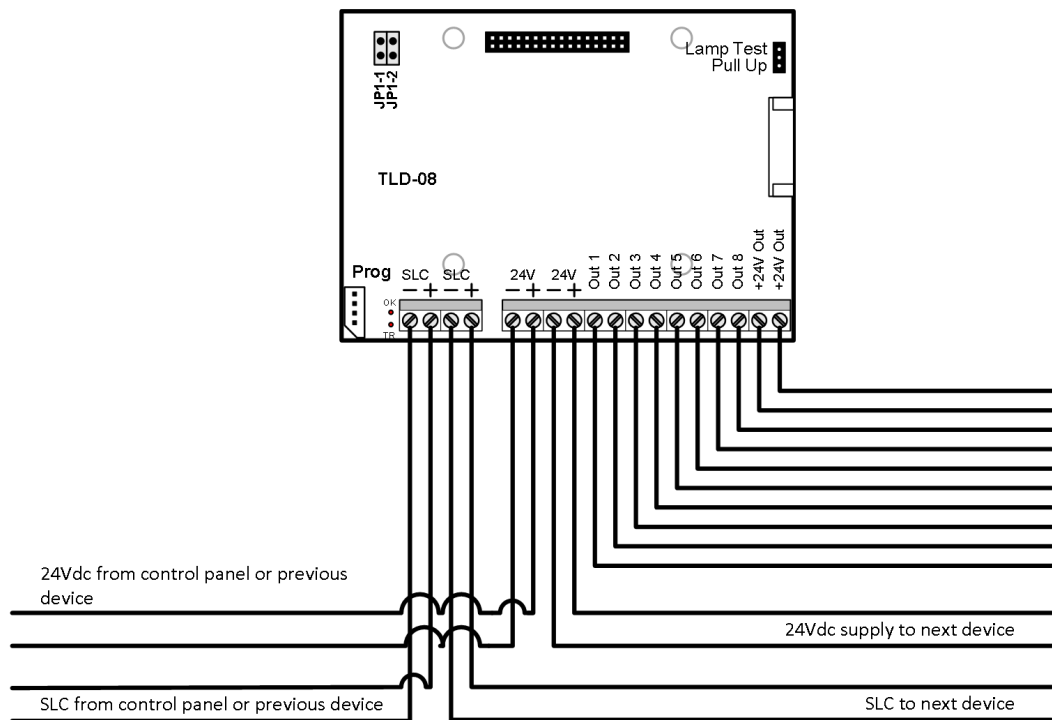

**Figure 2 Connect the bottom card**

### 3.2.8 Connect outputs

Connect LED indicators as per figure 3 and 4, and relays as per figure 5.

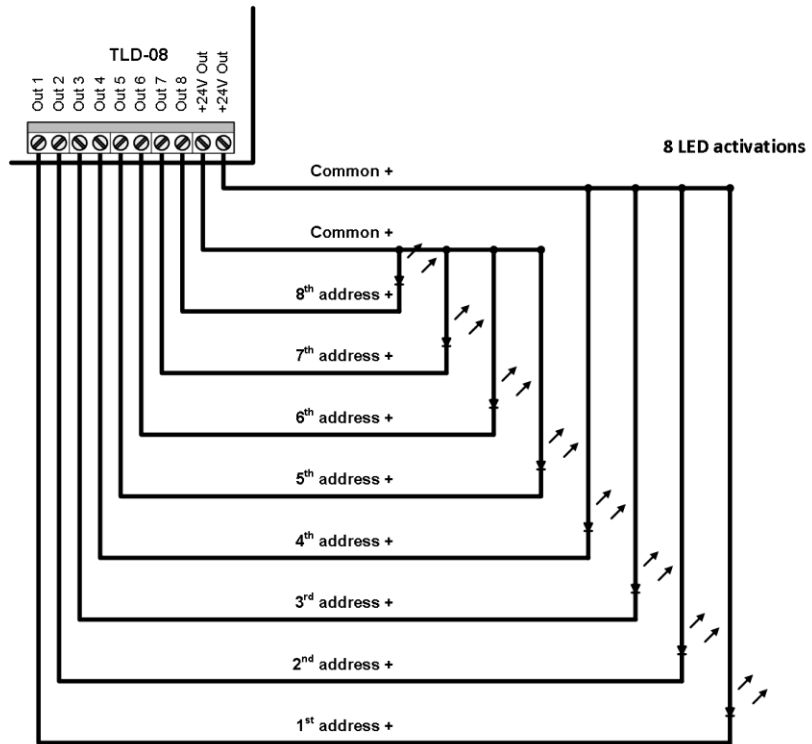

**Figure 3** TLD-08 LED connections – note that +24VOut are common to all open collector outputs

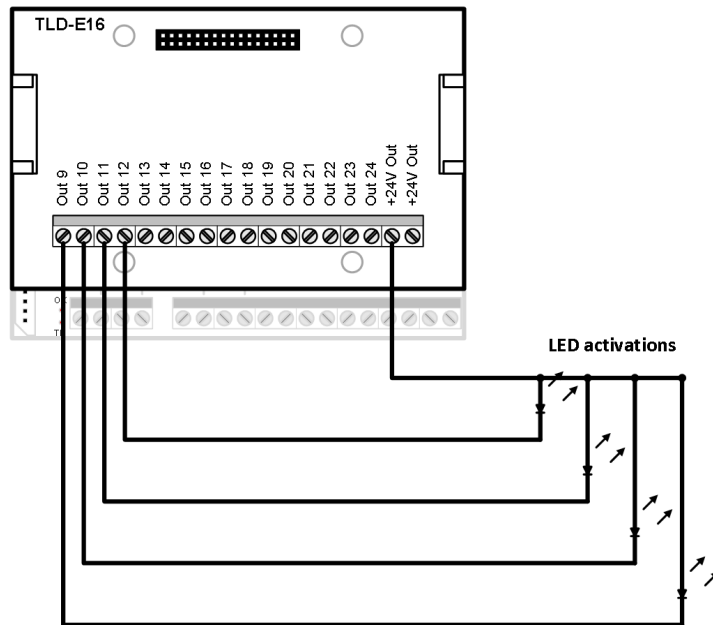

**Figure 4** TLD-E16 LED connections – note that +24VOut are common to all open collector outputs

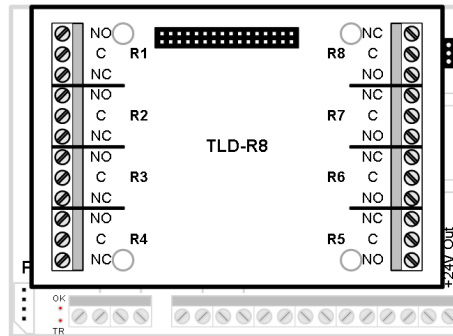

**Figure 5 Dry contact relays in TLD-R8 card.**

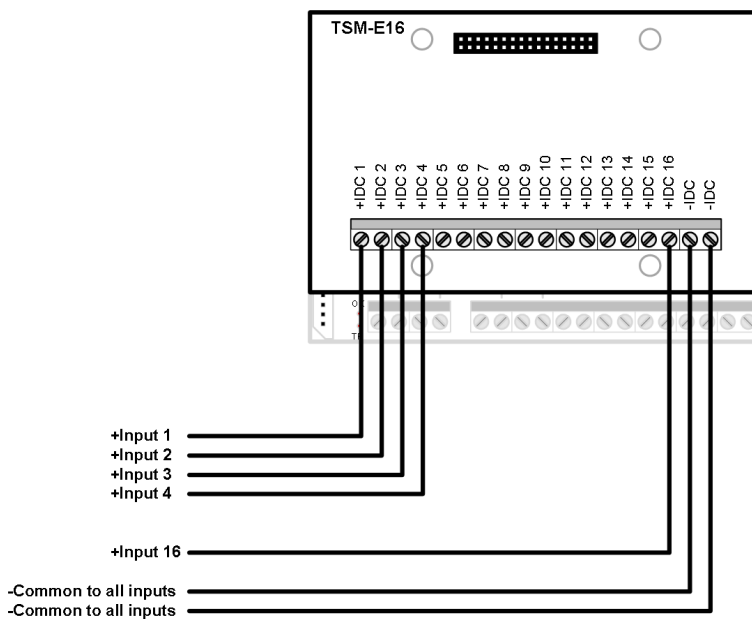

**Figure 6 Input connection to TSM-E16 – note that -IDC are common to all inputs**

## 4 Specification

### 4.1 Common to all subassemblies

Operating Temperature range.....	0°C – +49°C
Relative Humidity Range .....	10% – 93% non-condensing
Operating Voltage	
(from control panel via SLC) .....	21 V, modulated
(from control panel or auxiliary power supply) .....	24 Vdc nominal ± 10%
Maximum current consumption (SLC) .....	250µA (quiescence mode) 2.5mA (Alarm)
Maximum Current Consumption from 24Vdc supply .....	1.5mA (quiescence state)
Maximum Current Consumption from 24Vdc supply (Alarm)	
TLD-08.....	3.2mA
TLD-08 + TSM-E16.....	5.0mA
TLD-08 + TLD-E16 .....	3.5mA
TLD-08 + TLD-R8 .....	23.0mA

### 4.2 TLD-08 (main board)

Programmable outputs.....	8 open collector, unsupervised
output type .....	open collector, supplies minus
NFPA type .....	Class B
current protection .....	electronic
activation logic .....	programmable
Maximum line impedance .....	10Ω
Max current	
each output .....	50mA
all outputs concurrently .....	280mA

### 4.3 TLD-E16 installed on a TLD-08

Programmable outputs.....	16 open collector, unsupervised
output type .....	open collector, supplies minus
NFPA type .....	Class B
current protection .....	electronic
activation logic .....	programmable
Maximum line impedance .....	10Ω
Max current	
each output .....	50mA
all outputs concurrently .....	280mA

### 4.4 TLD-R8 installed on a TLD-08

Programmable outputs.....	8 dry contact relays
unsupervised, not current limited	
activation logic .....	programmable
maximum dry contact values.....	1.5A / 30Vdc
<b>Relay contacts are unsupervised, not current limited– same room connection only.</b>	

## 4.5 TSM-E16 installed on a TLD-08

---

Inputs.....	16 switch inputs
Supervised, current limited	
NFPA Classification .....	Class B
Current protection .....	electronic current limit
EOL Resistor .....	20K – use P/N EOL-20
Maximum line impedance .....	10Ω
Alarm resistance (selectable).....	close contact or 3.9KΩ

**All values are nominal. Specifications are subject to change without prior notice**

## 5 Certification

Telefire's TLD-24 Addressable Switch / Output Module has the following approvals:

- EN 54 Approved
- UL 864 Listed
- GOST Compliant
- CP 10 Compliant
- SI 1220 Approved
- CE Marked

Paragraph above is LastPage. Delete this paragraph onwards  
**Heading Base**

## **6 Heading 1**

### **6.1 Heading 2**

#### **6.1.1 Heading 3**

##### **6.1.1.1 Heading 4**

###### **6.1.1.1.1 Heading 5**

###### **6.1.1.1.1.1 Heading 6**

###### **6.1.1.1.1.1.1 Heading 7**

###### **6.1.1.1.1.1.1.1 Heading 8**

###### **6.1.1.1.1.1.1.1.1 Heading 9**

**Caption Base**

**Figure 7 Caption Figure**

Figure

**Table 4 Caption Table**

**Screen 1 Caption LCD**

```
LCD_40  
00000000011111111122222222223333333334  
1234567890123456789012345678901234567890
```

```
LCD_20  
00000000011111111112  
12345678901234567890
```

Body Text

Body Text Indent

Body Text Indent 2

Body Text Indent 3

List

List 2

List 3

• List Bullet

• List Bullet 2

• List Bullet 3

List Continue

List Continue 2

List Continue 3

1. List Number

1. List Number 2

1. List Number 3

Header

Header Base

Header Next

Footer

Emphasis

## 6.2 Tables







### 6.3 Standards Requirements

---

EN 54     EN 54 Requirement

EN 12094     EN 12094 Requirement

UL     UL Requirement

CP 10     CP 10 Requirement

GOST     GOST Requirement

IS 1220     IS 1220 Requirement

NFPA 72     NFPA 72 Recommendation

## 6.4 Notes and Warnings

---

***i***

Note

Separator

**!**

Warning